



US005833690A

# United States Patent [19]

[11] Patent Number: **5,833,690**

Yates et al.

[45] Date of Patent: **\*Nov. 10, 1998**

[54] **ELECTROSURGICAL DEVICE AND METHOD**

[75] Inventors: **David C. Yates**, West Chester; **Jesse J. Kuhns**, Cincinnati; **Steven H. Mersch**, Germantown; **Martin Madden**; **Richard P. Nuchols**, both of Loveland, all of Ohio

[73] Assignee: **Ethicon, Inc.**, Somerville, N.J.

[\*] Notice: The term of this patent shall not extend beyond the expiration date of Pat. No. 5,403,312.

[21] Appl. No.: **825,842**

[22] Filed: **Apr. 4, 1997**

### Related U.S. Application Data

[63] Continuation of Ser. No. 385,931, Feb. 3, 1995, abandoned, which is a continuation of Ser. No. 95,797, Jul. 22, 1993, Pat. No. 5,403,312.

[51] Int. Cl.<sup>6</sup> ..... **A61B 17/36**

[52] U.S. Cl. .... **606/52; 606/51; 606/50; 606/45**

[58] Field of Search ..... **606/37-42, 45-52, 606/142, 143, 205-208**

[56] **References Cited**

#### U.S. PATENT DOCUMENTS

1,798,902	3/1931	Raney .	
1,881,250	10/1932	Tomlinson .	
2,031,682	2/1936	Wappler et al. ....	606/46
4,375,218	3/1983	DiGeronimo .	
4,608,981	9/1986	Rothfuss et al. .	
4,633,874	1/1987	Chow et al. .	
4,655,216	4/1987	Tischer .....	606/51
4,671,274	6/1987	Sorochenko .	
4,985,030	1/1991	Melzer et al. ....	606/51
5,057,107	10/1991	Parins et al. ....	606/48
5,085,659	2/1992	Rydell .....	606/47
5,104,025	4/1992	Main et al. .	
5,151,102	9/1992	Kamiyama et al. ....	606/51
5,201,900	4/1993	Nardella .....	606/157

5,207,691	5/1993	Nardella .....	606/142
5,360,428	11/1994	Hutchinson, Jr. ....	606/45
5,389,098	2/1995	Tsuruta et al. ....	606/41
5,417,687	5/1995	Nardella et al. ....	606/32
5,443,463	8/1995	Stern et al. ....	606/51
5,445,638	8/1995	Rydell et al. ....	606/51
5,458,598	10/1995	Feinberg et al. ....	606/52

#### FOREIGN PATENT DOCUMENTS

0 517 244	12/1992	European Pat. Off. .	
0 518 230	12/1992	European Pat. Off. .	
WO 93/08754	5/1993	WIPO .	
94/24951	11/1994	WIPO .....	606/41
WO 94/24949	11/1994	WIPO .	
WO 94/24951	11/1994	WIPO .	

#### OTHER PUBLICATIONS

Automatically Controlled Bipolar Electrocoagulation—"COA-COMP", Neurosurg. Ref. (1984) 187-190; B. Vallofors and B. Bergdahl.

Instrument for Stomach Resection and Bowel Anastomosis Used During Closed Procedures, Department of Surgery of Mukachevo City Hospital, N.G. Vittenberger, Jan.-Feb. 1958, First Issue (the 211th).

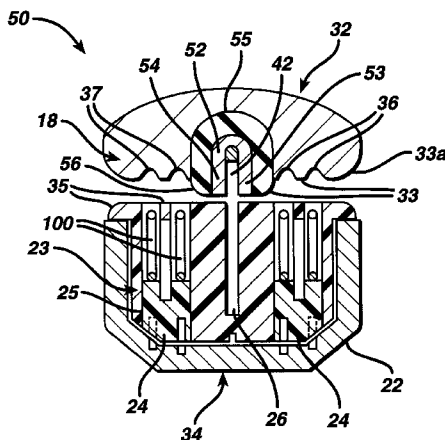
Two New Laparoscopic Instruments: Bipolar Sterilizing Forceps and Uterine Manipulator; Corson, Stephen L.; Medical Instrumentation, vol. 11, No. 1, (Jan.-Feb. 1977).

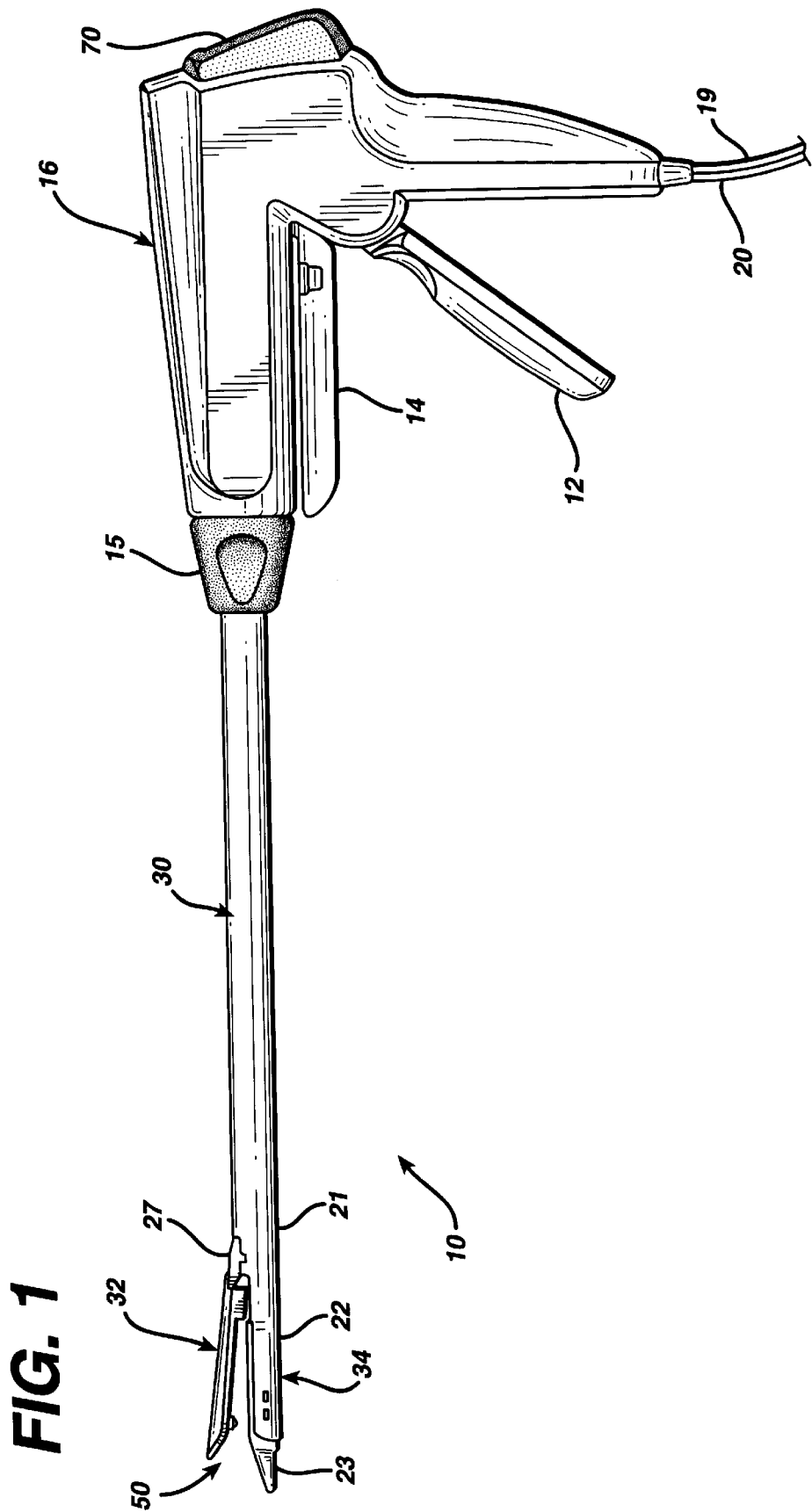
Primary Examiner—Michael Peffley  
Attorney, Agent, or Firm—Bernard Shay

[57] **ABSTRACT**

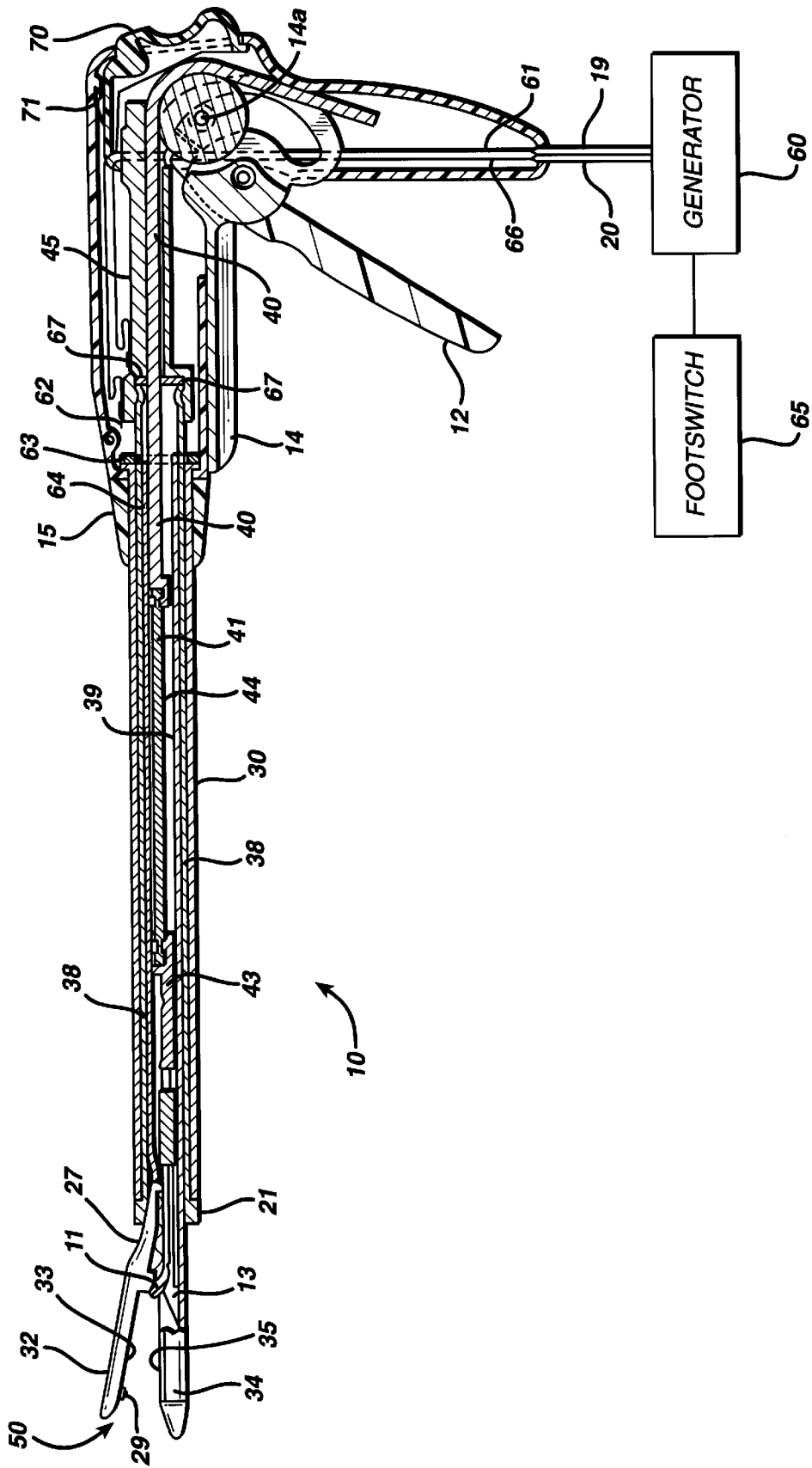
An electrosurgical instrument is provided for cauterization and/or welding of tissue of varying impedances, thicknesses and vascularity especially in the performance of endoscopic procedures. The instrument compresses the tissue between one pole of a bipolar energy source located on one interfacing surface, and a second interfacing surface. A second pole is located one of the two interfacing surfaces. In a preferred embodiment, the second pole is located on the same interfacing surface as the first pole and an insulator electrically isolates the two poles. A preferred application of the invention is in a cutting instrument wherein a hemostatic line is formed along a cut line using RF energy.

**11 Claims, 11 Drawing Sheets**

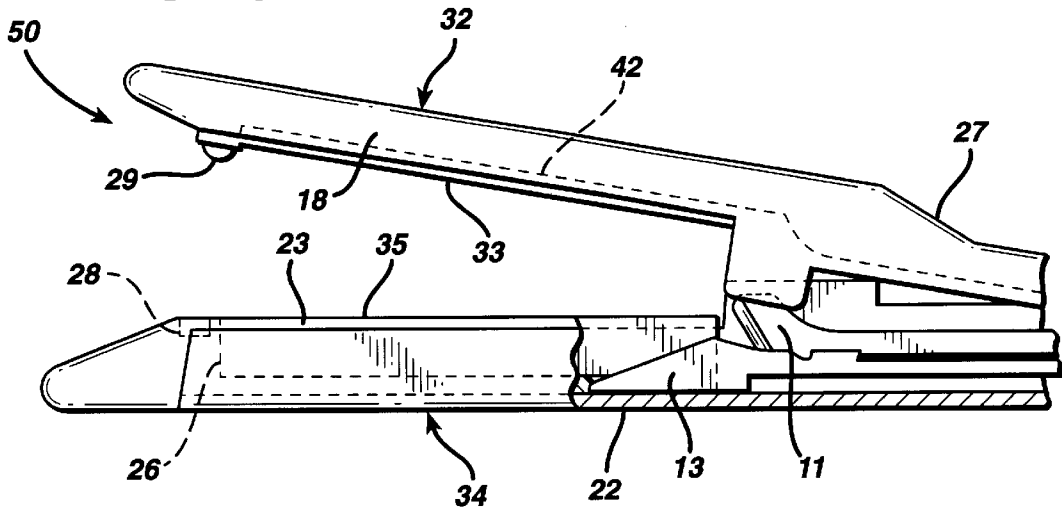




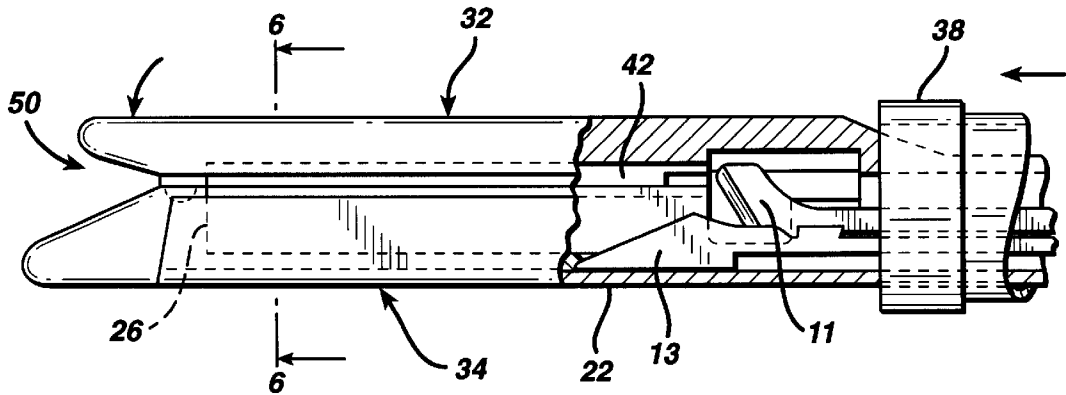
**FIG. 2**



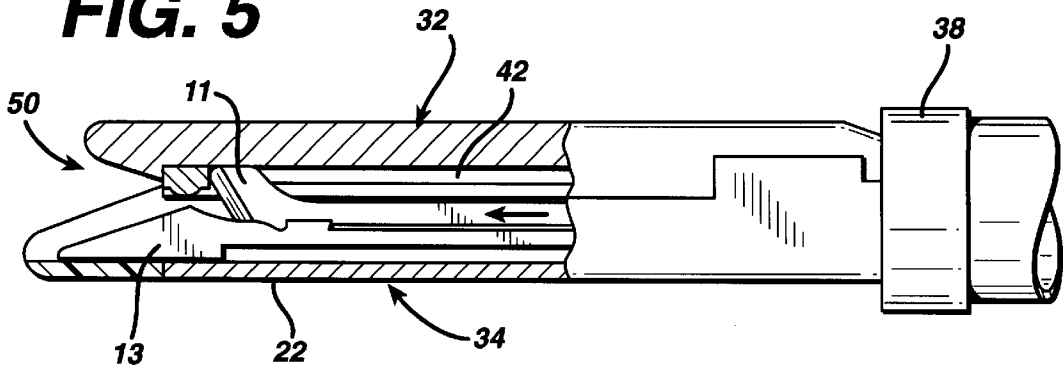
**FIG. 3**



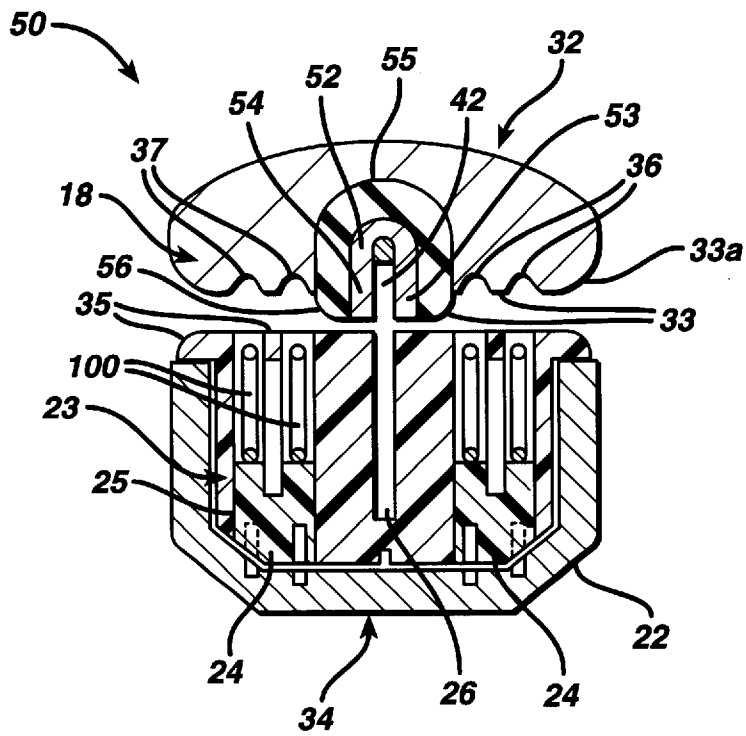
**FIG. 4**

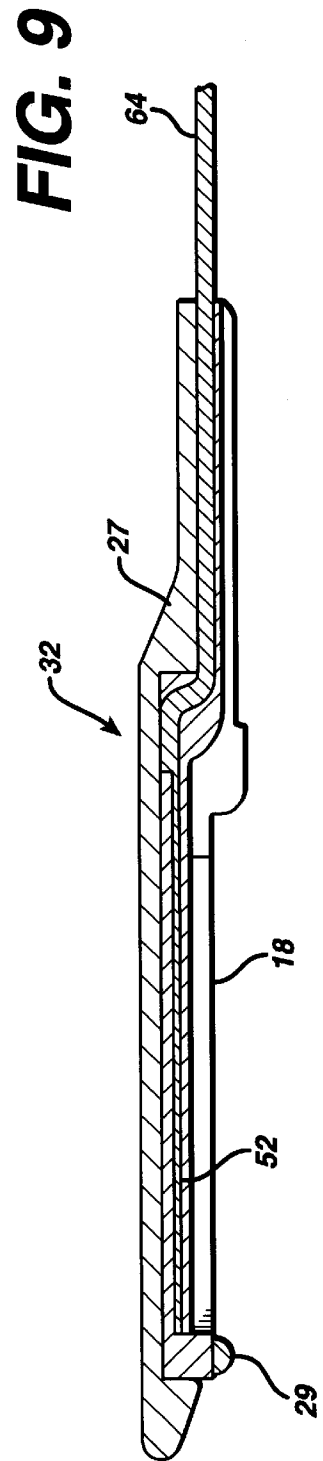
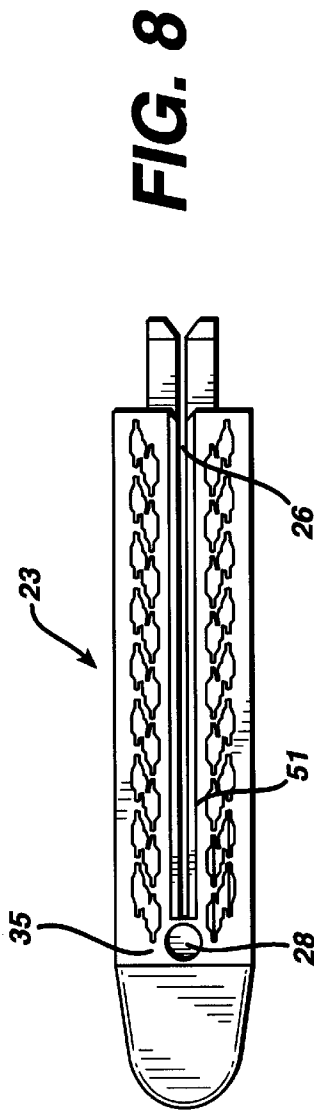
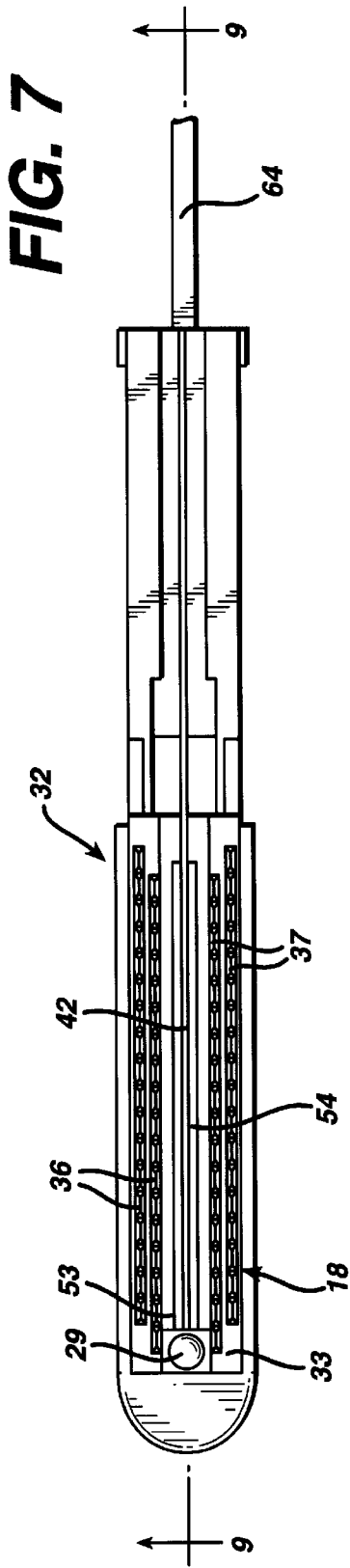


**FIG. 5**

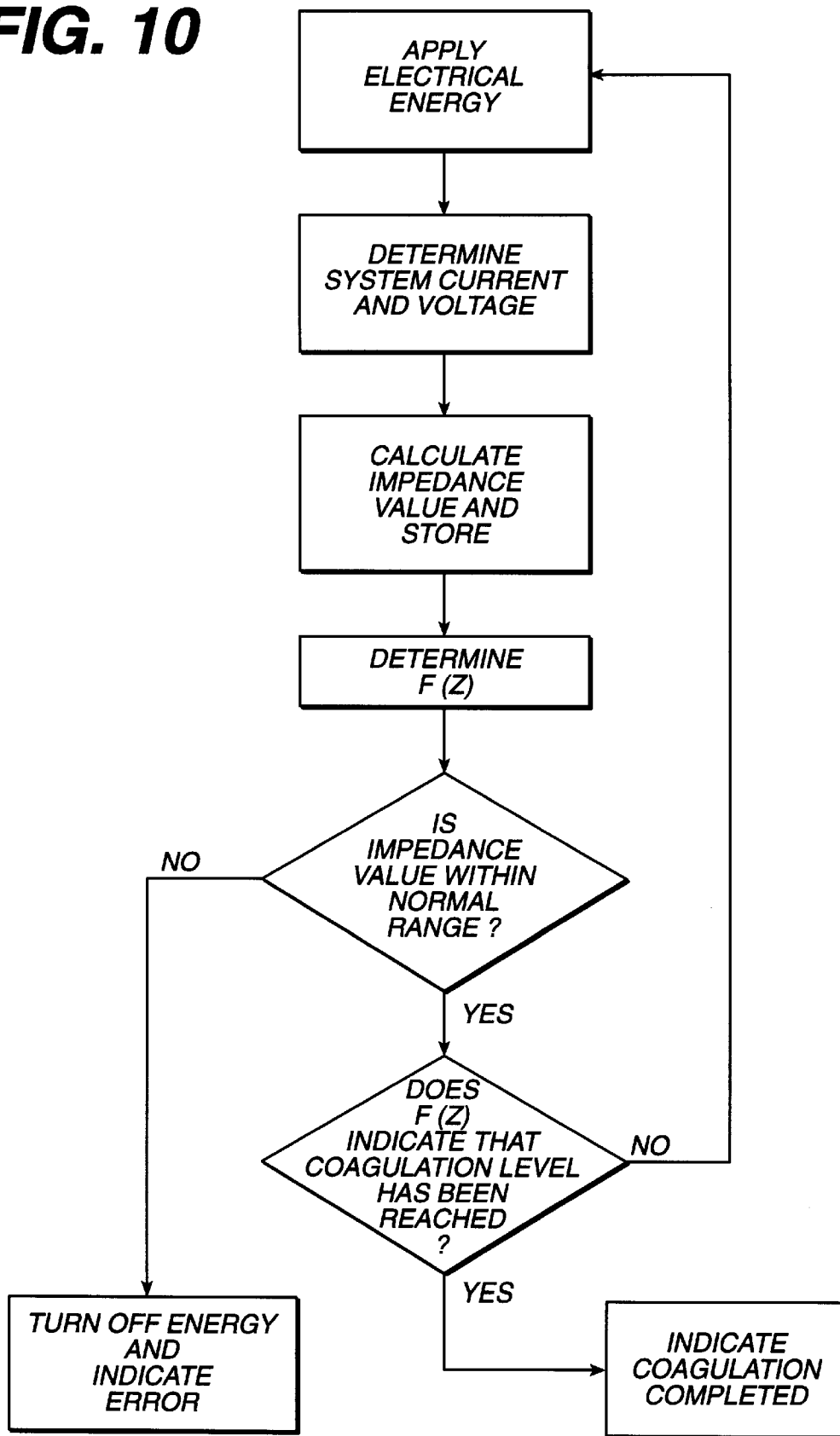


**FIG. 6**

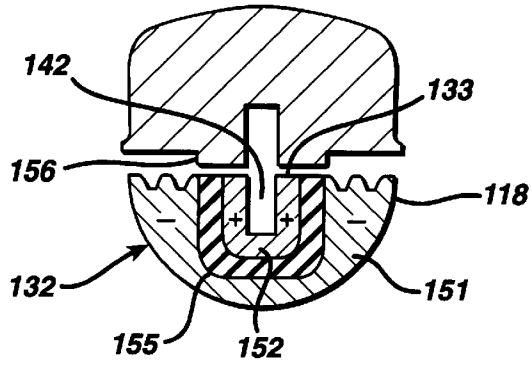




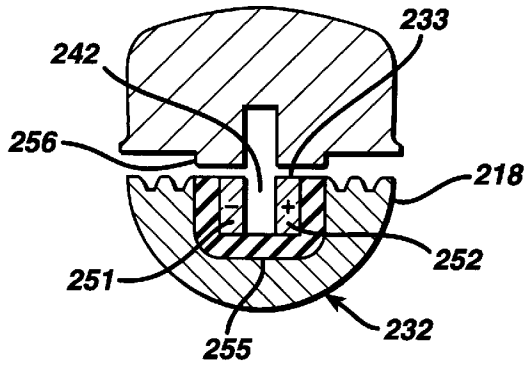
**FIG. 10**



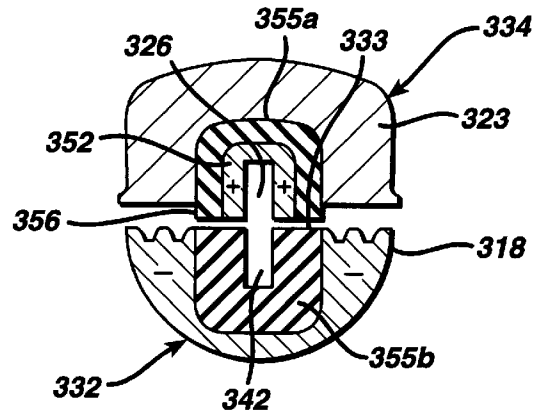
**FIG. 11**



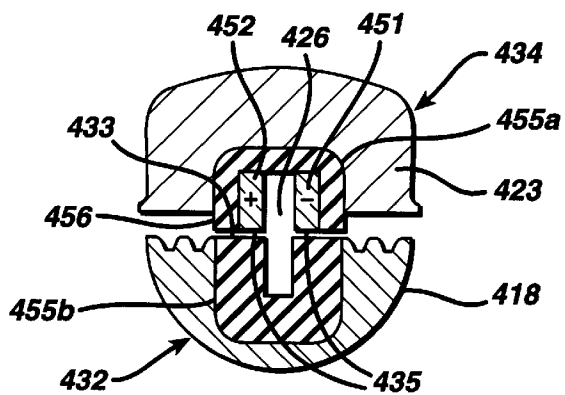
**FIG. 12**



**FIG. 13**

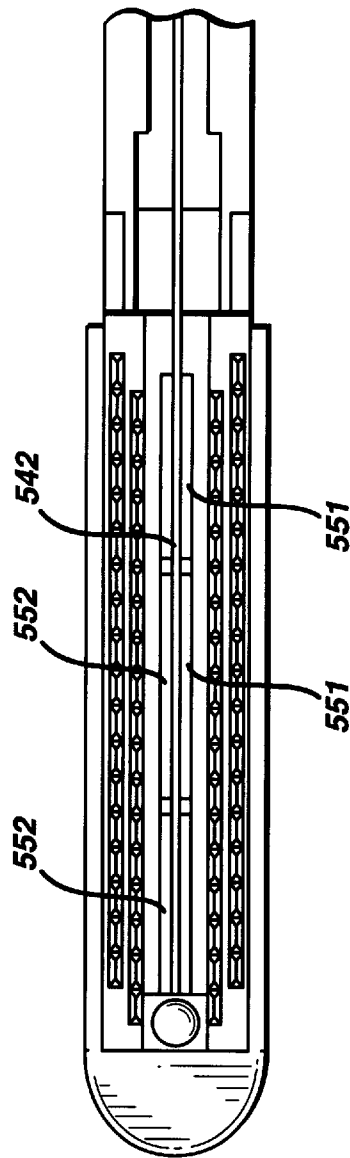


**FIG. 14**

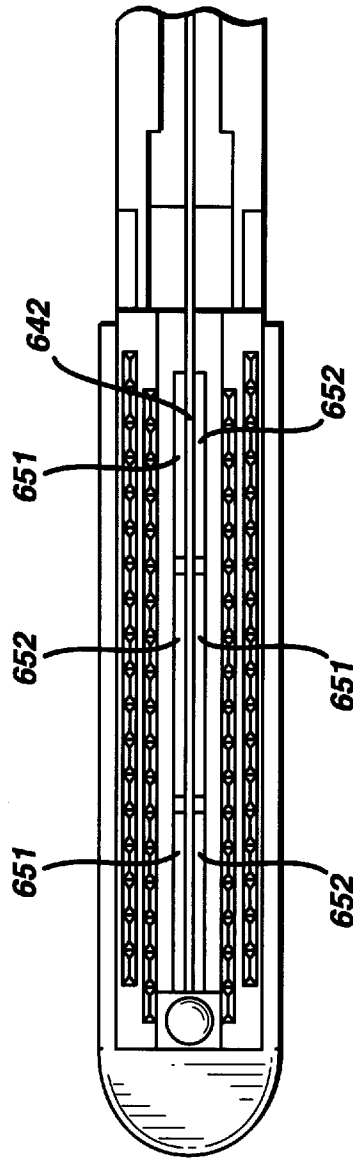




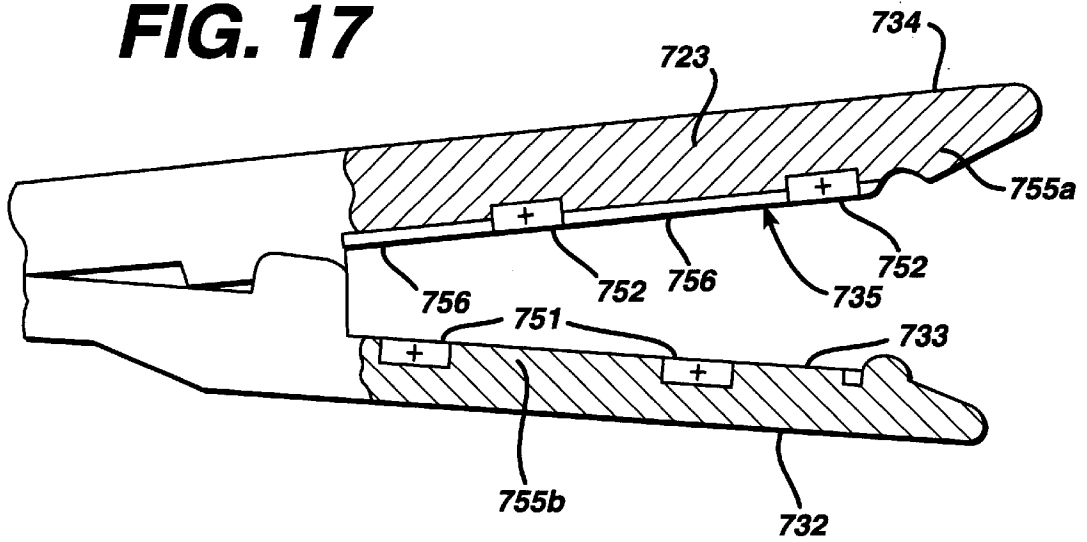
**FIG. 15**



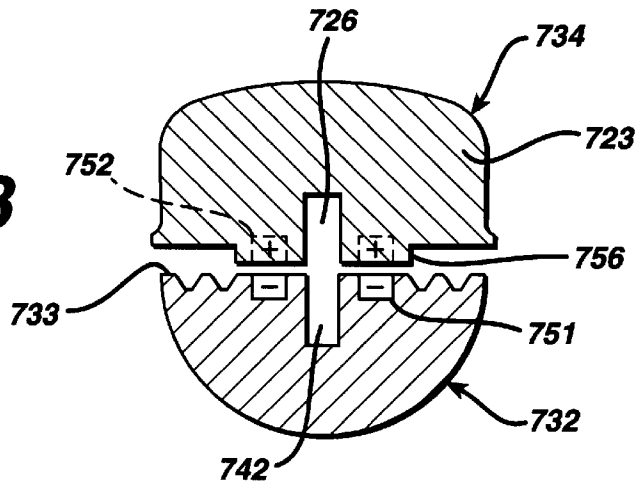
**FIG. 16**



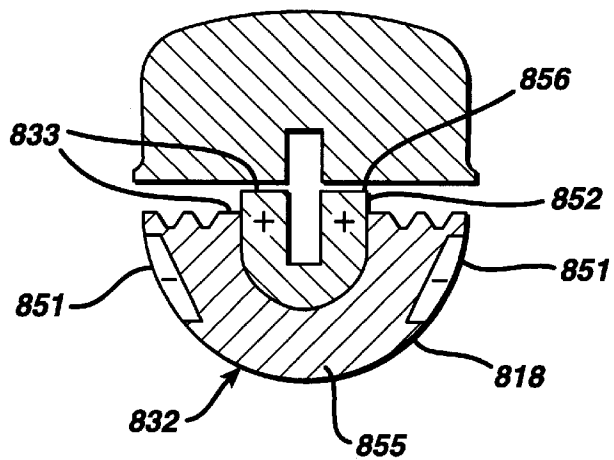
**FIG. 17**



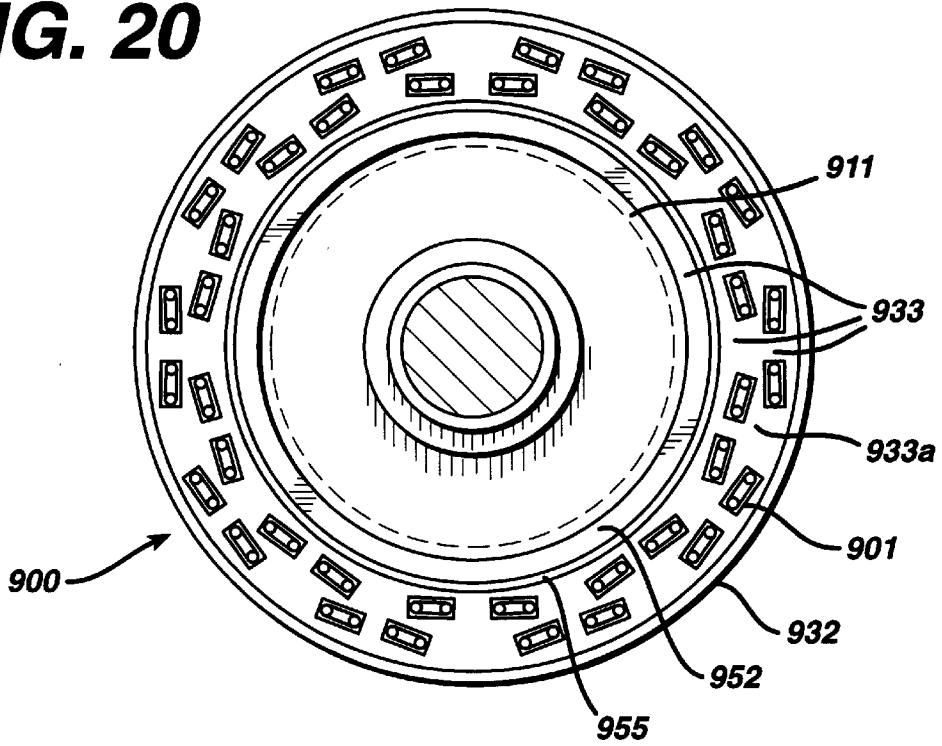
**FIG. 18**



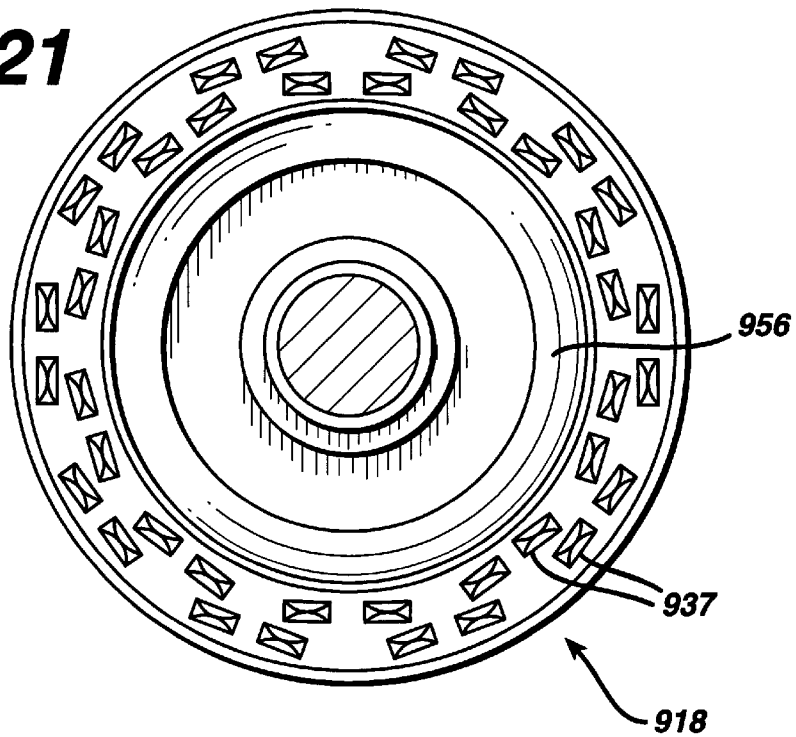
**FIG. 19**



**FIG. 20**



**FIG. 21**



## ELECTROSURGICAL DEVICE AND METHOD

This is a continuation of application Ser. No. 08/385,931, filed Feb. 3, 1995 (now abandoned) which is a continuation of Ser. No. 08/095,797 filed Jul. 22, 1993, now U.S. Pat. No. 5,403,312.

### FIELD OF THE INVENTION

This invention relates to an electrosurgical instrument for cauterization, coagulation and/or tissue welding in the performance of surgical procedures, especially endoscopic procedures.

### BACKGROUND OF THE INVENTION

Surgical procedures requiring cutting of tissue can cause bleeding at the site of the cutting. Before surgeons had the means to control bleeding many surgical procedures were quite difficult to perform because of excessive blood loss. Hemostasis is even more crucial in endoscopic or laparoscopic surgery where if the bleeding is not kept under control, the laparoscopy must be abandoned and the patient's body cut to perform open surgery so that inaccessible bleeding may be controlled.

Thus, various techniques have been adapted to control bleeding with varying degrees of success such as, for example, suturing, applying clips to blood vessels, and stapling, as well as electrocautery and other thermogenic techniques. Advances in tissue joining, tissue repair and wound closure also have permitted surgical procedures previously not possible or too risky.

Initially, suturing was one of the primary means for providing hemostasis and joining tissue. Before other hemostatic and tissue repair means were introduced, surgeons had to spend a great deal of time sewing the tissue of patients back together.

Surgical clips were introduced as a means to close off blood vessels, particularly when cutting highly vascularized tissue. Application of surgical clips, however, can be cumbersome in certain procedures. The vessels must be identified. Then a clip must be individually applied on both sides of the intended cut of each identified vessel. Also, it may be difficult to find some vessels, particularly where the vessel is surrounded by fatty tissue.

Surgical staplers have been effective in decreasing the amount of time it takes to fasten tissue together. There are various types of surgical staplers. Staplers have been used for tissue joining, and to provide hemostasis in conjunction with tissue cutting. Such devices include, for example, linear and circular cutting and stapling instruments. Typically, a linear cutter has parallel rows of staples with a slot for a cutting means to travel between the rows of staples. This type of surgical stapler secures tissue for improved cutting, joins layers of tissue, and provides hemostasis by applying parallel rows of staples to layers of surrounding tissue as the cutting means cuts between the parallel rows. These types of cutting and stapling devices have been used successfully in procedures involving fleshy tissue such as muscle or bowel, particularly in bowel resection procedures. Circular cutting and stapling devices have successfully been used, for example, in anastomotic procedures where a lumen is rejoined. However, the results with cutting and stapling devices have been less than optimum where the procedure involves cutting highly vascularized tissue, such as mesentery or adnexa, which are prone to having hemostasis problems.

Electrocautery devices have also been used for effecting hemostasis. Monopolar devices utilize one electrode associated with a cutting or cauterizing instrument and a remote return electrode, usually adhered externally to the patient. More recently, bipolar instruments have been used because the cauterizing current is generally limited to tissue between two electrodes of the instrument.

Bipolar forceps have been used for cutting and/or coagulation in various procedures. For example, bipolar forceps have been used in sterilization procedures where the fallopian tubes are sealed off. Generally, bipolar forceps grasp tissue between two poles and apply electrical current through the grasped tissue. Bipolar forceps, however, have certain drawbacks, some of which include the tendency of the current to arc between poles when tissue is thin or the forceps to short when the poles of the forceps touch. The use of forceps for coagulation is also very technique dependent and the forceps are not adapted to simultaneously cauterize a larger area of tissue.

Bipolar scissors have been disclosed where two scissors blades act as two electrodes having insulated shearing surfaces. This device mechanically cuts tissue as coagulating electrical current is delivered to tissue in the current path. Bipolar scissors are also highly technique dependent in their use.

### SUMMARY OF THE INVENTION

It is therefore an object of the present invention to provide a hemostatic electrosurgical instrument which can efficiently provide hemostasis in multiple tissue types and thicknesses, e.g., in fleshy or vascular tissue areas, and high, low or combination impedance tissues. Hemostasis is used herein to mean generally the arresting of bleeding including by coagulation, cauterization and/or tissue joining or welding.

It is another object of the invention to provide a bipolar hemostatic device which is capable of being used to simultaneously cauterize or weld a relatively larger area or length of tissue than in previously known devices.

It is another object of the invention to provide a bipolar electrocautery device having elongated or bar electrodes.

Another object of the invention is to provide a hemostatic means for providing a line of coagulation adjacent to a cutting path of a cutting means for dividing tissue.

Another object of the invention is to provide a cutting and stapling device with an electrocautery means for tissue welding or cauterization along a cutting path.

These and other objects of the invention are described in an electrosurgical device having an end effector with opposing interfacing surfaces associated with jaws for engaging tissue therebetween, and two electrically opposite poles located on one or both of the opposing surfaces. The poles are isolated from each other with an insulating material, or, where the poles are on opposite interfacing surfaces, they are offset from each other so that they are not diametrically opposed from each other on interfacing surfaces.

An electrosurgical instrument of a preferred embodiment compresses tissue in a compression zone between a first interfacing surface and a second interfacing surface and applies electrical energy through the compression zone. The first interfacing surface is comprised of: a first pole of a bipolar energy source, which interfaces with the compressed tissue in the compression zone; and a second pole electrically isolated from the first pole and located on the same or opposite interfacing surface. Electrically isolated poles are defined herein to mean electrodes isolated from each other

by an insulating material in the end effector and/or offset from each other on opposing surfaces.

In a preferred embodiment, the compression zone is an area defined by a compression ridge on one of the interfacing surfaces which compresses the tissue against the other interfacing surface. Also, there may be a compression ridge on both interfacing surfaces. A coagulation zone is defined by the first pole, the second pole, and an insulator insulating the first pole from the second pole. The second pole, located on one of the interfacing surfaces, is generally adjacent to the insulator on the same interfacing surface or across from the insulator on an opposing surface. This arrangement electrically isolates the two poles and enables the current path between the first and second poles to cross through a desired area of tissue.

It is believed that the tissue compression normalizes tissue impedance by reducing structural differences in tissue which can cause impedance differences. Compression also stops significant blood flow and squeezes out blood which acts as a heat sink, particularly when flowing through blood vessels. Thus, compression optimizes delivery of energy to tissue in part by enabling the rate of energy delivery to exceed the rate of dissipation due to blood flow. The arrangement of the electrodes, which make up the poles, is important to ensure that the current passing between the two poles passes through the compression zone. Also, insulation or isolation of the opposite poles from each other on the instrument permits tissue compression without shorting of the instrument poles or electrical arcing common in bipolar instruments.

Thus, the tissue compression and the arrangement of the electrodes permit more efficient cauterization and offer the advantage of achieving hemostasis in a wide range of tissue impedance, thickness and vascularity.

Compression is preferably balanced against causing unacceptable tissue damage from excessive compression. A gap between jaws can be varied depending on the intended application of instrument or the thicknesses of tissue on which the instrument is used.

In an alternative embodiment of the invention, the first pole is located on a first interfacing surface of a first jaw and the second pole is located on the same jaw as the first pole, but not on the interfacing surface.

The present invention also provides a device capable of coagulating a line or path of tissue along or lateral to a cut line or a cutting path. In one embodiment, the first pole comprises an elongated electrode. The elongated electrode along with the adjacent insulator form a ridge to compress the tissue to be cauterized. The second pole is adjacent the insulator on an opposite side of the insulator from the first pole.

In one preferred embodiment, a cutting means for cutting tissue is incorporated into the device and the device provides hemostatic lines adjacent to the path of the cutting means. Of course, cutting may occur at anytime either before, during or after cauterization or welding. In one variation of this preferred embodiment, stapling means is provided on one or both sides of the cutting path.

In one embodiment, an indicator means communicates to the user that the tissue has been cauterized to a desired or predetermined degree.

In another embodiment, the coagulation is completed prior to any mechanical cutting, i.e., actuation of the cutting means. If an indicator means is used, once tissue is cauterized, the cutting means may be actuated to cut between the parallel bars while the rows of staples are applied to the tissue.

In another embodiment, the hemostatic device is incorporated into a linear cutter similar to a linear cutting mechanical stapler. In this embodiment the hemostatic device comprises two parallel and joined elongated electrode bars which form one pole, and a slot for a cutting means to travel between the bars. Optionally, one or more rows of staples may be provided on each side of the slot and bars to provide additional hemostasis. In operation, tissue is clamped between two jaws. Electrical energy in the form of radio frequency current is applied to the compressed tissue to cauterize the blood vessels along the two parallel bars.

Another embodiment provides a means for detecting abnormal impedances or other electrical parameters which are out of a predetermined range. For example, the means for detecting may be used to indicate when the instrument has been applied to tissue exhibiting impedances out of range for anticipated good coagulation. It may also be used for detecting other instrument abnormalities. It is possible to detect the abnormal condition, for example, by using comparisons of normal ranges of initial tissue impedances in the interface electronics. This could be sensed in the first few milliseconds of the application of RF energy and would not present a significant therapeutic dose of energy. A warning mechanism may be used to warn the user when the impedance is out of range. Upon repositioning of the instrument, the same measurement criteria would apply and if the tissue impedance was again out of range, the user would again be warned. This process would continue until the normal impedance range was satisfied and good coagulation could be anticipated.

Similarly another embodiment provides a tissue welding and cauterizing cutting device similar to an intraluminal stapler. Preferably, the poles are formed in two concentric circle electrodes separated by an insulator. The electrodes which make up the poles may be located on either the stapler cartridge or the anvil.

These and other objects of the invention will be better understood from the following attached Detailed Description of the Drawings, when taken in conjunction with the Detailed Description of the invention.

#### DETAILED DESCRIPTION OF THE DRAWINGS

FIG. 1 is a side elevational view of an endoscopic electrocautery linear stapling and cutting instrument of one embodiment of the present invention;

FIG. 2 is a side cross sectional view of the instrument of FIG. 1;

FIG. 3 is a partial cross sectional view of the distal end of the instrument of FIG. 1 in an open position;

FIG. 4 is a partial cross sectional view of the distal end of the instrument of FIG. 1 in a closed, unfired position;

FIG. 5 is a partial cross sectional view of the distal end of the instrument of FIG. 1 in a closed, fired position;

FIG. 6 is a front cross sectional view of the distal end of the instrument of FIG. 3 taken along the line 6—6;

FIG. 7 is a bottom isolated view of the anvil jaw of the instrument of FIG. 1;

FIG. 8 is a top isolated view of a cartridge of the instrument of FIG. 1;

FIG. 9 is a side cross sectional view of the jaw of FIG. 7 along the line 9—9;

FIG. 10 is a flow chart illustrating a feedback system of the present invention;

FIG. 11 is a front cross sectional view of the end effector of another embodiment of the present invention;

FIG. 12 is a front cross sectional view of the end effector of another embodiment of the present invention;

FIG. 13 is a front cross sectional view of the end effector of another embodiment of the present invention;

FIG. 14 is a front cross sectional view of the end effector of another embodiment of the present invention;

FIG. 15 is a bottom isolated view of the anvil of another embodiment of the present invention;

FIG. 16 is a bottom isolated view of the anvil of another embodiment of the present invention;

FIG. 17 illustrates a cross sectional view of the distal end of another embodiment of the present invention;

FIG. 18 is front cross sectional view of the end effector of FIG. 17;

FIG. 19 is a front cross sectional view of the end effector of another embodiment of the present invention;

FIG. 20 is a top view of a cartridge of a circular cutter of the present invention;

FIG. 21 is a bottom view of the anvil of a circular cutter of the present invention.

#### DETAILED DESCRIPTION OF THE PREFERRED EMBODIMENTS

Referring now to FIGS. 1-9, there is illustrated a preferred embodiment of the present invention. An endoscopic electrocautery linear cutting and stapling instrument 10 is shown having a body 16 coupled to a shaft 30 with a lumen extending therethrough and an end effector 50 extending from the distal end 21 of the shaft 30. The shaft 30 is formed of an insulative material and has an electrically conductive sheath 38 extending through its lumen. A channel 39 extending through the sheath 38 guides co-axial movement of a driver means 44 within the channel 39. In this particular embodiment, the driver means 44 includes a firing trigger 14 associated with the body 16, coupled to a flexible firing rod 40 coupled to a driving rod 41, coupled to a block 43. The block 43 is coupled to a cutting means 11 and a staple driving wedge 13, which the driving means 44 advances by way of the block 43 into the end effector 50.

The end effector 50 comprises two interfacing jaw members 32, 34. The end effector 50 is secured by way of jaw member 34 to the channel 39. The jaw member 32 is movably secured to jaw member 34. The body 16 has a clamping trigger 12 for closing the jaws 32, 34 which longitudinally advances a close rack 45 coupled to the proximal end of the sheath 38. The close rack 45 advances the sheath 38 co-axially through the shaft 30. The sheath 38 advances over a camming surface 27 of jaw 32 to close the jaws 32 and 34 onto tissue situated between the jaws. As described in more detail below, the close rack 45 also acts as a switch to close the circuit which communicates electrical energy to the end effector 50.

Referring now to FIGS. 3-9 an enlargement of the end effector 50 of the instrument 10 is illustrated. The jaw members 32 and 34 are shown in an unclamped position in FIG. 3, in a clamped, unfired position in FIG. 4 and in a clamped, fired position in FIG. 5. Jaw member 32 comprises an anvil 18, a U-shaped first pole 52 extending longitudinally with respect to the jaw 32, and a U-shaped insulating material 55 surrounding the outside of the first pole 52. Jaw member 32 has an inner surface 33 which faces an inner surface 35 of jaw 34. The inner surface 33 includes first pole 52 which comprises two electrically communicating electrode bars 53, 54 comprised of aluminum, extending substantially along the length of the inner surface 33. The bars

53, 54 are separated by a knife channel 42 extending longitudinally through the first pole's center to form its U-shape. The surface of the bars are formed in flat strips to provide more surface area contact with tissue. Two series of pockets 36, 37 located on anvil 18, for receiving staple ends, extend along the inner surface 33, lateral to and outside of bars 53, 54 respectively. The electrode bars 53, 54 and the insulating material 55 form a ridge 56 extending out relative to the anvil portion 33a of the inner surface 33 (FIG. 6). The anvil 18 is formed of an electrically conductive material and acts as a second pole electrically opposite to the first pole. The anvil 18 is isolated from the first pole 52 by the U-shaped insulating material 55.

Jaw member 34 comprises a cartridge channel 22 and a cartridge 23. The cartridge 23 includes a track 25 for the wedge 13, knife channel 26 extending longitudinally through the center of the cartridge 23, a series of drivers 24 extending into track 25 and staples 100 arranged in two sets of parallel double rows. When tissue is engaged between the jaws 32, 34, the driver means 44 may be actuated or fired using trigger 14 to advance the cutting means 11 and wedge 13 through the engaged tissue to staple and cut the tissue. When the firing mechanism 14 is actuated, the wedge 13 is advanced through the track 25 causing the drivers 24 to displace towards the staples 100, thereby driving the staples 100 through tissue and into anvil pockets 36, 37.

A gap pin 29 located on the inner surface 33 towards the tip of the anvil 18 fits into a gap 28 is formed on the inner surface 35 of the cartridge 23. The gap 28 and gap pin 29 serve to align the staples 100 with the pockets 36, 37 and the knife channels 42, 26 with each other.

A knob 15 located on the distal end of the body 16 rotates the shaft 30, sheath 38, channel 39 and end effector 50 which are directly or indirectly coupled to the knob 15 so that the knob 15 may be used for rotational placement of the end effector jaws 32, 34.

Bipolar energy is supplied to the end effector 50 from an electrosurgical generator 60 through wires 19, 20 extending into the body 16 of the instrument. The generator 60 is user controlled by way of a footswitch 65.

Wire 19 which provides electrical current to the first pole, is coupled through a wire or other electrical contact means 61 to electrical contact 62, associated with the first pole, located on the distal end of close rack 45. Wire 20 which carries the current of the opposite pole, is coupled through a wire or other electrical contact means 66 to a disc contact 67 located at the distal end of the close rack 45 and electrically isolated from contact 62.

A disc contact 63, associated with the first pole, located at the distal end of the body 16 is in electrical communication with a wire or other contact means 64. Contact means 64 extends through channel 39 to end effector jaw 32 where it contacts first pole 52. The disc contact 63 permits the knob 15 to rotate while contact is maintained between the disc contact 63 and the contact means 64. The contact means 64 is electrically insulated from the sheath 38.

When the clamping trigger 12 is actuated, the close rack 45 moves distally so that the contact 62 comes in electrical communication with the disc contact 63 and the disc contact 67, associated with the second pole 51, comes in electrical contact with the electrically conductive sheath 38. The sheath 38 moves over the camming surface 27 of the electrically conductive anvil 18 which acts as the return electrode. Thus the electrical circuit is closed when and only when the clamping trigger 12 is closed.

In operation, the end effector 50 of the instrument is located at a tissue site where tissue is to be cut. The jaw

members **32, 34** are opened by pressing a release button **70** which releases a button spring **71** and permits the close rack **45** to move proximally. Tissue is then placed between the interfacing inner surfaces **33, 35** respectively of the jaw members **32, 34**. The clamping trigger **12** is squeezed to cause the sheath **38** to move over the camming surface **27** and thereby close the jaws **32, 34** and simultaneously close the electrical circuit as described above. The gap spacing pin **29** causes the anvil **18** to be held roughly parallel to the cartridge **23**. The electrode bars **53, 54** and the insulating material **55**, which together form the ridge **56**, compress the tissue against the inner surface **35** of jaw member **34**. A gap of about between 0.012 and 0.022 inches exists between jaw members in the compression zone. A user then applies RF energy from the generator **60** using the footswitch **65** or other switch. Current flows through the compressed tissue between the first pole **52**, i.e. the bars **53, 54**, and the second pole **51**, i.e., the anvil **18**.

Preferably the bipolar energy source is a low impedance source providing radio frequency energy from about 300 kHz to 3 MHz. Preferably, the current delivered to the tissue is from 0.1 to 1.5 amps and the voltage is from 30 to 200 volts RMS.

An audible, visible, tactile, or other feedback system may be used to indicate when sufficient cauterization has occurred at which point the RF energy may be turned off. An example of such a feedback system is described below. After the RF energy is turned off, the cutting means **11** is advanced and the staples **100** are fired using the firing trigger **14**. Firing is accomplished by rotating the firing trigger **14** acting as a lever arm about pivot **14a**. The driver means **44** advances the cutting means **11** and wedge **13**. The cutting means **11** cuts the tissue in between the bars **53, 54** where the tissue has been cauterized. Thus, the cut line is lateral to the coagulation lines formed by the bar electrodes. The wedge **13** simultaneously advances the drivers **24** into the staples **100** causing the staples **100** to fire through tissue and into the pockets **36, 37** of the anvil **18**. Staples **100** are applied in two longitudinal double rows on each side of the cutting means **11** as the cutting means cuts the tissue.

Operation of linear staplers are known in the art and are discussed, for example, in U.S. Pat. Nos. 4,608,981, 4,633, 874, and U.S. application Ser. No. 07/917,636 incorporated herein by reference.

In one embodiment the cartridge provides multifire stapling capabilities by replacing the double row of staples with a single row. In the laparoscopic stapling and cutting devices presently in use, a single shot replaceable cartridge is used. In order to provide better hemostasis, this type of stapler was designed to provide a double row of staples for each parallel row. Because of the size of the space necessary to contain the double row of staples, a refireable cartridge with stacked staples has not been preferred because of the additional space required for stacking staples. In the multifire stapling embodiment a single row of staples is used. Using a single row of staples permits stacking of staples in the space previously occupied by the second row of staples, providing multifire capabilities. In a further embodiment, no staples are required and the electrical current lines provide the necessary hemostasis.

A preferred embodiment of the present invention includes a feedback system designed to indicate when a desired or predetermined degree of coagulation has occurred. This is particularly useful where the coagulation zone is not visible to the user. In a particular embodiment, the feedback system measures electrical parameters of the system which include coagulation level.

The feedback system may also determine tissue characteristics at or near a coagulation zone which indicate degree of coagulation. The electrical impedance of the tissue to which the electrical energy is applied may also be used to indicate coagulation. Generally, as energy is applied to the tissue, the impedance will initially decrease and then rise as coagulation occurs. An example of the relationship between electrical tissue impedance over time and coagulation is described in Vaellfors, Bertil and Bergdahl, Bjoern "Automatically controlled Bipolar Electrocoagulation," Neurosurg. Rev. p. 187-190 (1984) incorporated herein by reference. Also as desiccation occurs, impedance increases. Tissue carbonization and or sticking to instrument as a result of over application of high voltage may be prevented using a feedback system based on tissue impedance characteristics. Other examples of tissue characteristics which may indicate coagulation include temperature and light reflectance.

Referring to FIG. 10, a flow chart illustrates a feedback system which is implemented in a preferred embodiment of the present invention. First, energy is applied to the tissue. Then the system current and voltage applied to the tissue is determined. The impedance value is calculated and stored. Based on a function of the impedance, for example, which may include the impedance, the change in impedance, and/or the rate of change in impedance, it is determined whether desired coagulation has occurred. If coagulation has occurred to a predetermined or desired degree, an indication means indicates that the energy should be turned off. Such an indication means may include a visible light, an audible sound or a tactile indicator. The feedback means may also control the generator and turn the energy off at a certain impedance level. An alternative embodiment provides a continuous audible sound in which the tone varies depending on the impedance level. An additional feature provides an error indication means for indicating an error or instrument malfunction when the impedance is below a normal minimum and/or above a maximum range.

FIGS. 11-14 illustrate alternative configurations of an end effector. In FIG. 11 the first pole **152** and the second pole **151** are both located on the same jaw **132** having the anvil **118**. The U-shaped first pole **152** forms the knife channel **142**. A U-shaped insulator **155** surrounds the first pole **152** except on the surface **133** so that it is electrically isolated from the second pole **151**. The compression ridge **156** is formed on the cartridge which is made from an electrically non-conductive material. The ridge **156** compresses tissue against the first pole **152** and insulator **155** to form a tissue compression zone.

In FIG. 12, the first pole **252** and the second pole **251** are both located on the same jaw **232** having the anvil **218**. The first pole **252** and the second pole **251** each are located on opposing sides of the knife channel **242**. An insulator **255** surrounds the poles **251, 252** except on the surface **233** so that the poles **251, 252** are electrically isolated from each other. The compression ridge **256** is formed on the cartridge which is made from an electrically non-conductive material. The ridge **256** compresses tissue against the poles **251, 252** and insulator **255** to form a tissue compression zone.

In FIG. 13, second pole **351** is located on the jaw **332** having the anvil **318** while the first pole **352** is located on the cartridge **323**. The U-shaped first pole **352** forms the knife channel **326** and is surrounded by insulator **355a**. A U-shaped insulator **355b** forms the knife channel **342** in jaw **332**. Except for the insulator **355b**, the jaw is formed of an electrically conductive material which makes up the second pole **351**. The first pole **352** and the insulator **355a** form the



compression ridge **356** which compresses tissue against the surface **333** of jaw **332** to form a compression zone. The insulator **355b** is of sufficient width that it prevents poles **351, 352** from contacting when the jaws **332,334** are closed.

In FIG. **14**, the first pole **452** and the second pole **451** are both located on the jaw **434** having the cartridge **423**. The first pole **452** and the second pole **451** each are located on opposing sides, forming the knife channel **426** through the cartridge **423**. An insulator **455a** surrounds the poles **451, 452** except on the surface **435**, so that the poles **451, 452** are electrically isolated from each other. The compression ridge **456** is formed on the cartridge **423** and forms a compression zone by compressing tissue against an insulator **455b** disposed on the surface **433** of the jaw **432**.

FIG. **15** illustrates an alternative embodiment. The first and second poles **551, 552** and knife channel **542** are arranged in a similar configuration as in FIG. **12** except that the first and second poles **551** and **552** each comprise a series of electrically connected electrodes staggered along the length of the knife channel with insulating material in between staggered electrodes.

FIG. **16** illustrates staggered electrodes as in FIG. **15** but with first pole electrodes **652** and second pole electrodes **651** alternating along the length of the knife channel **642** and on each side of the knife channel **642**.

FIGS. **17** and **18** illustrate another embodiment in which first and second poles **751, 752** each comprise staggered electrodes. In this embodiment, the first pole **752** is staggered along each side of the knife channel **126** and located on the compression ridge **756** formed on the cartridge **723**. The second pole **751** is staggered along each side of the knife channel **742** on the surface **733** of jaw **732**. As can be seen from FIG. **18**, the poles **751, 752** are vertically aligned, but as illustrated in FIG. **17**, are staggered so that when the jaws **732, 734** are closed, the poles are electrically isolated from each other by insulators **755a, 755b**.

FIG. **19** illustrates an alternative embodiment of the end effector. The first pole **852** and the second pole **851** are both located on the jaw **832** having an anvil **818**. The first pole **852** forms the ridge **856** for compressing tissue in a compression zone and is located on interfacing surface **833**. The second pole **851** is located on the side of the anvil **818** and not on interfacing surface **833**.

FIGS. **20** and **21** illustrate a circular cutter of the present invention with stapling means. FIG. **20** illustrates the stapler cartridge **900** with an interfacing surface **933**. A double row of staple apertures **901** through which staples are driven into tissue are staggered about the outer circumference of the surface **932**. A first pole **952** encircles the inner circumference of the surface **933**. An insulator **955** electrically isolates the first pole **952** from the portion **933a** of the surface **933** surrounding the staple apertures. The staple aperture portion **933a** is formed of an electrically conductive material and acts as a second pole. A circular cutting knife **911** is recessed within the cartridge **900** radially inward from the inner circumference of the surface **933**.

FIG. **21** illustrates an anvil **918** with pockets **937** for receiving staples and a compression ridge **956** for compressing tissue against the first pole **952** and insulator **955** of the cartridge. The circular cutter is operated similarly to the circular stapler described in U.S. Pat. No. 5,104,025 incorporated herein by reference. Prior to stapling and cutting however, tissue welding electrical current may be delivered between the first pole **952** and the staple aperture portion **933a** to tissue.

In an alternative embodiment, the circular cutter may be used without staples. Electrical current is delivered through

the poles to weld and coagulate tissue, then the knife may be advanced to cut tissue in a procedure such as an anastomosis.

Several variations of this invention has been described in connection with two specific embodiments involving endoscopic cutting and stapling. Naturally, the invention may be used in numerous applications where hemostasis is desired. Accordingly, will be understood by those skilled in the art that various changes and modifications may be made in the invention without departing from its scope, which is defined by the following claims and their equivalents.

What is claimed is:

1. An electro-surgical instrument comprising:

a shaft having a distal end;

an end effector located at the distal end of the shaft, said end effector adapted to receive electro-surgical energy therein, said end effector comprising:

first and second pivotally connected elements comprising first and second opposed tissue contacting surfaces respectively, said surfaces moveable relative to each other from an open, spaced-apart position for positioning tissue therebetween, to a closed position for approximating the tissue, at least a portion of one of said surfaces being an elongated electrical conductor at least partially surrounded by electrically insulating regions which form a second portion on said surface and said electrical conductor being arranged to receive the electro-surgical energy, and each of said first and second opposed tissue contacting surfaces having a proximal and distal portion and a longitudinal axis extending proximal to distal through said end effector wherein said elongated electrical conductor is arranged to be substantially parallel to said longitudinal axis;

a first channel formed in said first surface,

a second channel formed in said second surface, wherein said first and second channels form an enclosed cutting path when said surfaces are in said closed position, a cutting element moveable along said cutting path in a direction from the proximal to distal portions of said surfaces to cut tissue positioned between said surfaces, wherein said cutting path is enclosed by said first and second elements.

2. The electro-surgical instrument of claim 1 wherein said first and second elements further comprise first and second outer surfaces, respectively, wherein said first and second outer surfaces are arranged to contain said cutting element therebetween when said cutting element is actuated.

3. The electro-surgical device of claim 1 wherein said cutting element comprises a mechanical cutting blade.

4. An electro-surgical instrument comprising:

a shaft having a distal end and a longitudinal axis;

an end effector located at the distal end of the shaft, said end effector adapted to receive electro-surgical energy therein, said end effector comprising:

first and second pivotally connected elements comprising first and second opposed tissue contacting surfaces respectively, said surfaces moveable relative to each other from an open, spaced-apart position for positioning tissue therebetween, to a closed position for compressing the tissue, at least a portion of one of said surfaces being an elongated electrical conductor at least partially surrounded by electrically insulative regions which form a second portion of said surface and said electrical conductor being arranged to receive the electro-surgical energy; and

## 11

a cutting element moveable within an enclosed cutting path to cut tissue positioned between said surfaces, wherein said first and second elements in said closed position define a compression zone.

5. The electrosurgical device of claim 4 wherein said first element further comprises a compression ridge wherein said compression ridge forms said compression zone.

6. An electrosurgical instrument comprising:

a shaft having a distal end and a longitudinal axis:

an end effector located at the distal end of the shaft, said end effector adapted to receive electrosurgical energy therein, said end effector comprising:

first and second pivotally connected elements comprising first and second opposed tissue contacting surfaces respectively, said surfaces moveable relative to each other from an open, spaced-apart position for positioning tissue therebetween, to a closed position for approximating the tissue, at least a portion of said surfaces being an elongated electrical conductor at least partially surrounded by electrically insulating regions which form a second portion of said surface and said electrical conductor being arranged to receive the electrosurgical energy, and

each of said first and second opposed tissue contacting surfaces having a proximal and distal portions; a cutting element moveable within an enclosed cutting path to cut tissue positioned between said surfaces, wherein said elements in said closed position define a closed area for compressing tissue to be treated with electrosurgical energy.

7. An electrosurgical instrument comprising:

a shaft having a distal end and a longitudinal axis;

an end effector located at the distal end of the shaft, said end effector adapted to receive electrosurgical energy therein, said end effector comprising:

first and second pivotally connected elements comprising first and second opposed tissue contacting surfaces respectively, said surfaces moveable relative to each other from an open, spaced-apart position for positioning tissue therebetween, to a closed position for approximating the tissue, one of said surfaces comprising a first portion and a second portion, said first portion being an elongated electrical conductor arranged to receive the electrosurgical energy, and said second portion at least partially surrounding said first portion and electrically non conductive of the electrosurgical energy, and a cutting element move-

## 12

able through an enclosed cutting path in said end effector to cut tissue positioned between said surfaces.

8. The electrosurgical device of claim 7 wherein each of said first and second opposed tissue contacting surfaces comprise proximal and distal portions;

wherein said cutting element is moveable in a direction from the proximal to distal portions of said surfaces to cut tissue positioned between said surfaces; and

wherein at least one of said first and second opposed tissue contacting surfaces includes a slot for receiving said cutting element.

9. A method for electrosurgically treating tissue comprising:

providing an electrosurgical instrument comprising:

a shaft having a distal end and a longitudinal axis; an end effector located at the distal end of the shaft, adapted to receive electrosurgical energy therein, said end effector comprising:

first and second pivotally connected opposed tissue contacting surfaces said surfaces moveable relative to each other from an open, spaced-apart position for positioning tissue therebetween, to a closed position for approximating the tissue, at least a portion of one of said surfaces being an elongated electrical conductor at least partially surrounded by electrically insulating regions which form a second portion of said surface said electrical conductor being and arranged to receive the electrosurgical energy, and

a cutting element moveable along an enclosed cutting path to cut tissue between said surfaces; clamping tissue between said surfaces; applying electrosurgical energy to treat said tissue; and cutting said tissue with said cutting element after electrosurgically treating tissue.

10. The method of claim 9 wherein said cutting element comprises a mechanical cutting blade and wherein the step of cutting tissue comprises mechanically cutting tissue with said mechanical cutting blade.

11. The method of claim 9 further comprising:

measuring the electrical impedance of the tissue to which electrosurgical energy is applied; and

prior to cutting said tissue, indicating to a user of said instrument when the tissue is coagulated to a desired degree.

\* \* \* \* \*